

产品规格承认书

Product Specification Confirmation

产品名称 (Product Name):	智能板铁锂 16 串 48V100A 同口带均衡 Smart BMS LiFePO4 16S 48V100A Common port with Balance	
产品型号 (Product Model):	DL-R25A-F16S100ATJ	
客户名 (Customer Name):		
客户料号 (Customer P/N):		
送样日期 Sample send date	版次 Version	文件编号 Document No.
	A0	
编制 PREPARED By	核准 (Verified)	审核 CHECKED By
颜立花	闫连红	杨飞贵
客户确认栏 CUSTOMER APPROVED		
确认意见 INSPEC.RESULT:		
客户签章 APPROVAL SIGNET:		
日期 Date:		
注意 (Note):		
<p>1.收到样机确认 OK 后请及时回签, 7 天内没有回签及问题反馈, 我司默认客户测试合格; 规格书中的图片为通用机型图片, 可能与送样样机有差异, 此份规格书达锂电子保留最终解释权 Please respond us timely after receiving the sample boards and confirm the samples whether they are ok or not There is no feedback given to us within 7 days., then we regard our customers' test is qualified;The attached picture in this specification is a common model picture,which may be different from the shipped sample. This specification is belong to Daly Electronics property, Who keep the final interpretation right on these parameters.</p> <p>2.客户批量前, 请在规格书中签字回传, 并说明详细功能说明, 我司才安排批量 Please sign and return it to Daly on the specification before starting mass production, and remark the detailed function description in this specification.</p>		

目录 Table of contents

1. 简介 Introduction.....	第 3 页
2. 产品概述及特点 Product overview and characteristics	第 3 页
3. 功能示意框图 Function Schematic Box Fig	第 4 页
4. 电气特性 Electrical properties	第 4 页
4.1 基本参数 Basic parameters.....	第 4~6 页
4.2 辅助模块参数 Auxiliary module parameters.....	第 6~7 页
4.3 可靠性参数 Reliability parameters.....	第 8 页
5.通信说明 Communication instructions	第 8 页
5.1 RS485 通信	第 9 页
5.2 CAN 通信.....	第 9 页
6.上位机说明 PC software Description	第 9 页
7.保护板尺寸图 BMS Dimensional drawing.....	第 9~10 页
7.1 接口引脚说明 Interface pin instructions.....	第 10~11 页
7.2 主要线材说明 Main line material description.....	第 11~12 页
8.接线示意图 Schematic diagram of wiring.....	第 12 页
8.1 接线说明 Description of wiring.....	第 12 页
8.2 接线注意事项 Precautions for wiring.....	第 13 页
9.保修 Warranty.....	第 13 页
10.注意事项 Note.....	第 13~14 页
11.特别说明 Special instructions.....	第 14 页

1.简介 Introduction

随着锂电池在锂电行业的广泛应用，对电池管理系统也提出了高性能、高可靠性及高性价比等要求。本产品是专门针对锂电池设计的 BMS，它能够实时采集、处理和存储电池组在使用过程中的信息数据，保证电池组的安全性、可用性和稳定性。

With the wide application of lithium battery in Lithium Battery Industry, high performance, high reliability and high cost performance are required for battery management system. This product is designed specifically for lithium-ion batteries in BMS, it can collect, process and store the information data of the battery in real time, and ensure the safety, availability and stability of the battery.

2.产品概述及特点 (Product Summary):

- ◆ 使用专业大电流走线设计及工艺，能经受超大电流冲击

Professional high current wiring design & workmanship, thus can withstand the shock of high current high .

- ◆ 外观采用注塑密封工艺，提升防潮，防元器件氧化程度，延长产品使用寿命

The appearance is sealed by injection molding process to improve moisture-proof and oxidation-proof components and prolong the service life of the products

- ◆ 具有防尘、防震、防挤压等防护功能

dust proof, shockproof, anti-squeezing and other protective functions

- ◆ 有完整的过充、过放、过流、短路、均衡功能

There is a complete over-charge, over-discharge, over-current, short-circuit, balance function

- ◆ 采用集成化的设计，将采集、管理、通信等功能集成于一体

With the integrated design, the collection, management, communication and other functions are integrated

- ◆ 具有通讯功能，可通过上位机对过流、过放、过流、充放电过流、均衡、过温、欠温、休眠、容量等参数进行设置

With communication function, it can set the parameters of over-current, over-discharge, over-current, charge-discharge, over-current, balance, over-temperature, under-temperature, dormant, capacity, etc.

3.功能示意框图 Functional Block Diagram

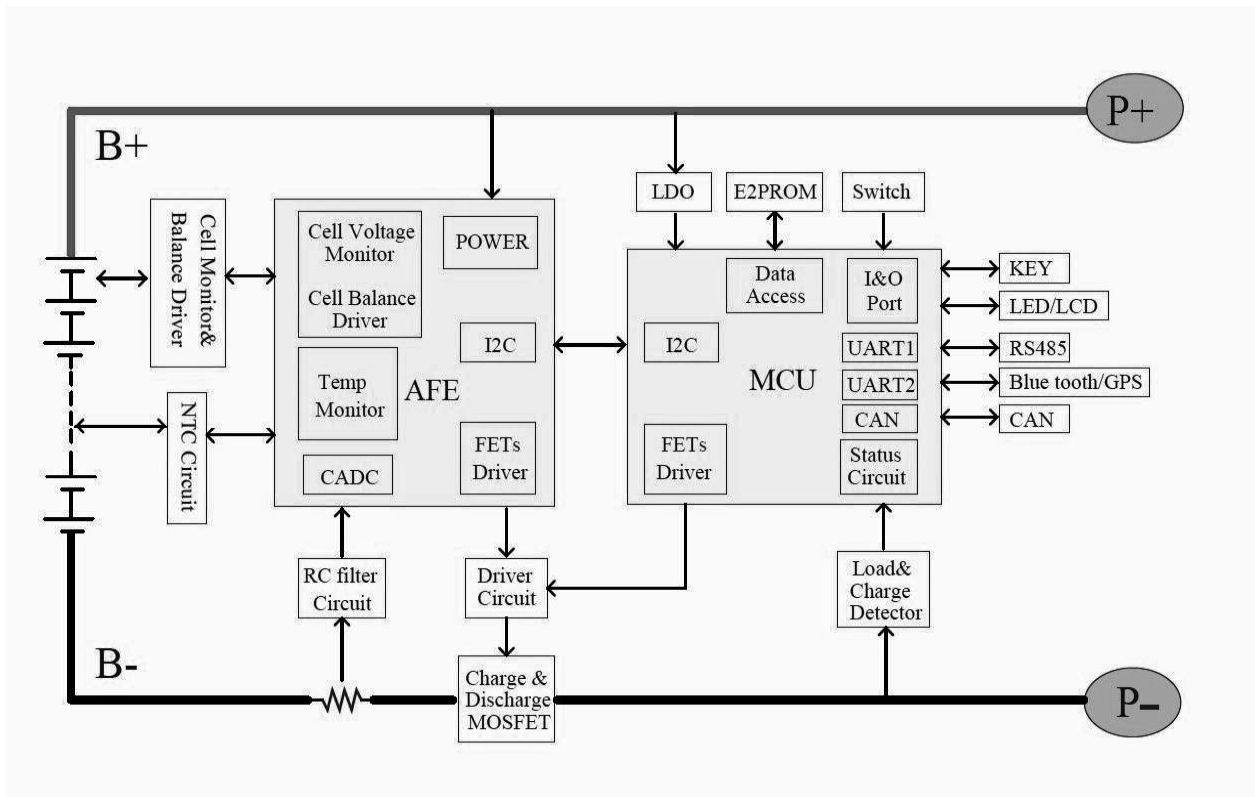

4.电气特性 Electrical characteristics

4.1 基本参数 Basic parameters

序号 No	检测内容 IT est content		出厂默认参数 Factory default parameters	单位 Unit	备注 Note
1	放电 Discharge	持续放电电流 Continuous discharge current	100	A	
	充电 Charging	充电电压 Charging voltage	58.4	V	
		持续充电电流 Continuous charging current	50	A	
2	均衡功能 Balanced	均衡开启电压 Balance detect Voltage	3.2	V	
		开启压差 Turn on the pressure difference	50	mV	默认值 set default
		均衡开启条件 Balanced opening condition	同时满足： At the same time to meet: 1.充电情况下 Charging case		

			2.达到设定平衡开启压差 Atain set balance open pressure difference 3.达到设定平衡开启电压 Balanced switching voltage set			
3	单体过充保护 Single overcharge protection	单体过充保护电压 Single overcharge protection voltage	3.75±0.05	V		
		单体过充保护延时 Single overcharge protection voltage	1	S		
		单体过充保护解除电压 Single overcharge protection and release voltage	3.65±0.05	V		
		单体过充保护解除延时 Release delay of single overcharge protection	1	S		
4	单体过放保护 Monomer over-discharge protection	单体过放保护电压 Single over-release protection voltage	2.2±0.05	V		
		单体过放保护延时 Time-lapse of single over release protection	1	S		
		单体过放保护解除电压 Single over release protection and release voltage	2.3±0.05	V		
		单体过放保护解除延时 Discharge delay of monomer over discharge protection	1	S		
5	总压过充保护 Total overcharge protection	总体过充保护电压 Overall overcharge protection voltage	60	V	Deviation <3%FSR	
		总体过充保护延时 Overall overcharge protection delay	1	S		
		总体过充保护解除电压 Overall overcharge protection release voltage	58.4	V		
		总体过充保护解除延时 Overall release delay of overcharge protection	1	S		
6	总压过放保护 Total pressure discharge protection	总体过放保护电压 Overall overcast protection voltage	35.2	V	Deviation <3%FSR	
		总体过放保护延时 Overall over-release protection delay	1	S		
		总体过放保护解除电压 Overall over-release protection and release voltage	36.8	V		
		总体过放保护解除延时 Overall over release protection release delay	1	S		
7	充/放电过流保护 Charge/Discharge overflow protection	放电过流 1 级告警电流 Discharge current level 1 alarm current	120±3%	A		
		放电过流 1 级告警延时 Discharge current level 1 alarm delay	1	S		
		放电过流 2 级保护电流 Discharge current level 2 protection current	150±3%	A		
		放电过流 2 级保护延时 Discharge current level 2 protection delay	1	S		
		解除条件	移除负载解除			

		Discharge conditions 充电过流保护电流 Charge the over current protection current	Removing the load is lifted		
		充电过流保护延时 Charge over current protection delay	150±3%	A	
		解除条件 Discharge conditions	1	S	
			移除充电器解除 Remove charger release		
8	短路保护 Remove charger release	短路保护条件 Short circuit protection conditions	外部负载短路 External load short circuit		
		短路保护延时 Short circuit protection delay	320	uS	
		短路保护解除 Short circuit protection is lifted	移除负载解除 Removing the load is lifted		
9	温度保护 Temperature protection	充电高温告警温度 Charging high temperature alarm temperature	60	°C	
		充电高温保护温度 Charging high temperature protection temperature	65	°C	
		充电高温保护延时 Charging high temperature protection delay	1	S	
		充电高温释放温度 Charging high temperature release temperature	63	°C	
		充电低温告警温度 Charge the low temperature alarm temperature	-35	°C	
		充电低温保护温度 Charging is the low- temperature protection temperature	-40	°C	
		充电低温保护延时 Charging low- temperature protection delay	1	S	
		充电低温释放温度 Charge it at a low temperature to release the temperature	-33	°C	
		放电高温告警温度 Discharge high temperature alarm temperature	65	°C	
		放电高温保护温度 Discharge high temperature protection temperature	70	°C	
		放电高温保护延时 Discharge high-temperature protection delay	1	S	
		放电高温释放温度 Discharge high temperature release temperature	63	°C	
		放电低温告警温度 Discharge low temperature alarm temperature	-35	°C	
		放电低温保护温度 Discharge the low- temperature protection temperature	-40	°C	
		放电低温保护延时 Discharge low- temperature protection delay	1	S	
		放电低温释放温度 Discharge at low temperature release temperature	-33	°C	

		温度保护解除条件 Temperature protection release conditions	达到恢复温度且断开负载 Reaching recovery temperature and dis load		
		温度个数 Number of temperatures	1	PCS	
10	压差告警 The pressure difference is reported to the police	压差大告警 The pressure difference is called to the police	0.5	V	达锂标配状态 DALY Standard Condition
		压差大告警恢复 Poor pressure big alarm recovery	0.45	V	
11	内阻 Internal impedance	主回路导通内阻 The main circuit leads through internal resistance	<20	mΩ	
12	消耗电流 consume current	工作时自耗电电流 Self-current current consumption during operation	35	mA	不包含模块自耗 module self-consumption is included
		休眠模式自耗电电流 Hibernate mode self- consumption current	800	uA	进入: 无通讯、无电流、无钥匙信号 Enter: no communication, no current, no key Spoon signal
		休眠时间 Sleep time	3600	S	
13	通讯方式 Communication method	<input type="checkbox"/> UART <input checked="" type="checkbox"/> RS485 <input checked="" type="checkbox"/> CAN <input checked="" type="checkbox"/> 蓝牙 Bluetooth <input type="checkbox"/> GPS <input type="checkbox"/> LCD <input type="checkbox"/> 电量显示模块 SOC indicator			
14	钥匙开关 Control switch	<input type="checkbox"/> 有 <input checked="" type="checkbox"/> 无			
15	保护板尺寸 BMS size	长*宽*高 (mm) Long * Width * High (mm) 166*65*24			

4.2 辅助模块参数 Auxiliary module parameters

序号 NO	名称 Name	电流 Current	是/否标配 Yes/no standard accessories	备注 Note
1	PACK 并联模块 Pack parallel module	<input type="checkbox"/> 2A	否 no	
		<input type="checkbox"/> 5A	否 no	
		<input type="checkbox"/> 15A	否 no	
2	加热模块	5~30A	否 no	1.当检测到环境温度低于 0°C时开始加热并断开充放电

	Heating Module			<p>When the ambient temperature is detected below 0 ° c, the heating is started and the discharge is disconnected.</p> <p>When the ambient</p> <p>2.当检测到环境温度高于 5°C时断开加热并可以充放电</p> <p>temperature is detected above 5 ° c, the heating is disconnected and the discharge can be charged</p>
--	----------------	--	--	--

4.3 可靠性参数 Reliability parameters

序号 NO	项 目 Item See	条 件 Article Part
1	检测精度 Detection accuracy	<p>电流检测精度 Current detection accuracy: $\leq (\pm 3\%FSR)$</p> <p>电压检测精度 voltage detection accuracy: $\leq \pm 15mV$</p> <p>温度检测精度 Temperature detection accuracy: $\leq 2^{\circ}C$ (常温下)</p> <p>SOC 平均精度 SOC average accuracy: $\leq 8\sim 10\%$ (受环境温度影响)</p>
3	信息存储 Information storage	<p>最大存储 380 条履历信息, 含保护次数, 当前总电压、电流、温度、SOC、等</p> <p>Max storage 380 resume information, including number of protection, current total voltage, current, temperature, SOC,, etc</p>
4	SOC 计量 SOC measurement	采用电流积分法 The current integration method is used
5	工作环境条件 Working environment conditions	工作温度:-20°C~60°C Operating temperature:-20°C~60°C
		相对湿度:5%~90%RH Relative humidity: 5%~90%RH
6	存储环境条件 Storage environment conditions	存储温度:-40°C~85°C Storage temperature: -40°C~85°C
		相对湿度:5%~75%RH Relative humidity:

5. 通信说明 Communication instructions

默认为 UART 通讯, 可定制客户 RS485、MODBUS、CAN、UART 等通讯协议

The default is UART communication, customizing communication protocols such as customer RS485, MODBUS, CAN, UART

5.1 RS485 通信

默认达锂 RS485 信协议，通过专用通讯盒与指定上位机进行通讯，波特率默认为 9600bps。从而在上位机端察看电池的各种信息，包括电池电压、电流、温度、状态、SOC、及电池生产信息等，可进行参数设置及相应控制操作，支持程序升级功能。（本上位机适用于 Windows 系列平台的 PC 机）。

The default lithium RS485 letter protocol, communication with the designated upper computer through the dedicated communication box, the port rate default is 9600bps. Thus, check the various information of the battery at the upper machine terminal, including the battery voltage, current, temperature, state, SOC, and battery production information, etc., and can conduct parameter setting and corresponding control operation to support the program upgrade function. (This upper bit computer is suitable for PC s on Windows series platforms).

5.2 CAN 通信

默认达锂 CAN 协议，通信速率 250KB/S。

Default is up to the lithium CAN protocol, with a communication rate of 250KB/S.

6. 上位机说明 PC software Description

上位机 DALY BMS-V1.0.0 功能主要分为六大部分：数据监控、参数设置、参数读取、工程模式、历史告警和 BMS 升级。

- 1、解析各模块发送的数据信息，然后将电压、温度、配置值等显示出来；
- 2、通过上位机向各模块配置信息；
- 3、生产参数校准；
- 4、BMS 升级。

The PC software DALY BMS-V1.0.0 function is mainly divided into six parts: data monitoring, parameter setting, parameter reading, engineering mode, historical alarm, and BMS upgrade.

- 1, parses the data information sent by each module, and then displays the voltage, temperature, configuration value, etc;
- 2, configures information to each module via the upper bit computer;
- 3, production parameter calibration;
- 4, BMS upgrade is available.

7. 保护板尺寸图（接口仅供参考，非常规标配，详情请参考 7.1 接口引脚说明）

BMS Dimensional drawing(interface for reference only, unconventional standard, please refer to 7.1 Interface pin specification)

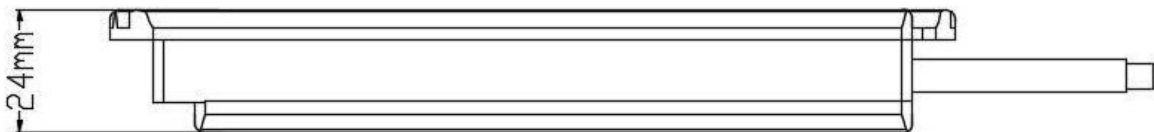

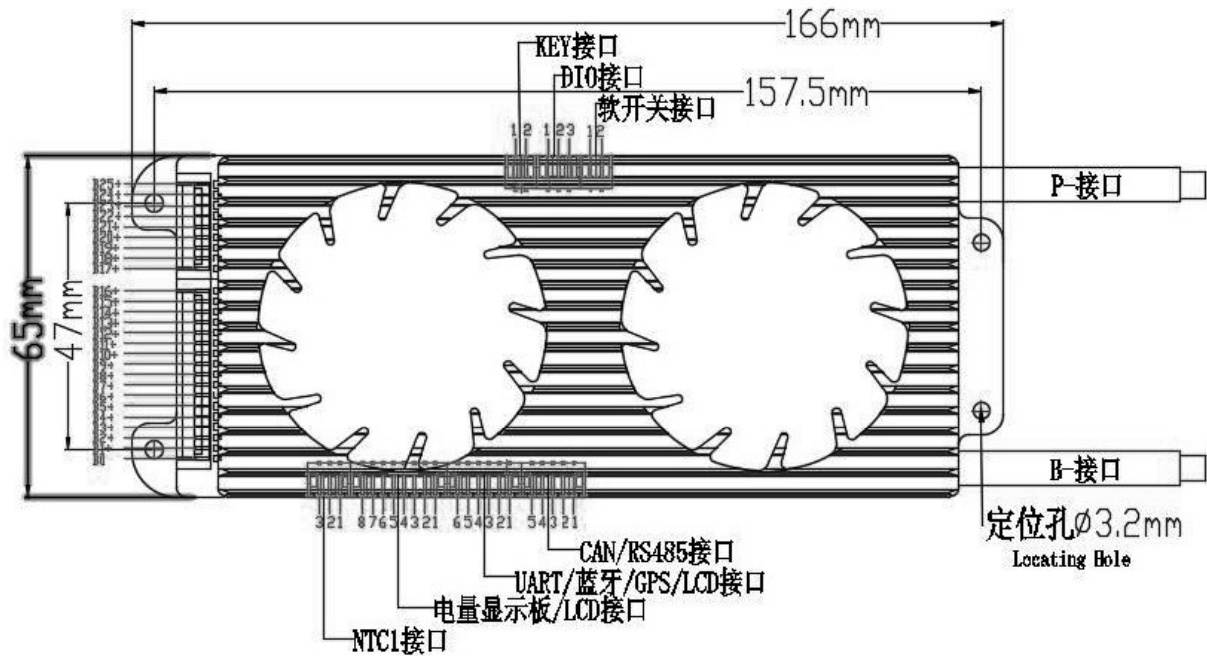

7.1 接口引脚说明 Interface pin instructions

接口名称 Interface name	Pin 脚	标号	定义说明 Description of definition
B-接口 (标配) Standard Parts	/	B-	电池总负, 接电池总负 Negative battery, negative battery
P-接口 (标配) Standard Parts	/	P-	保护板充放电负电极, 接充放电负端 Protective plate charge and discharge negative electrode, connect to the charge and discharge negative end
Connecting wire 采样线接口 (标配) Standard Parts PHB 2.0 17Pin 带扣	1	B0	接第 1 节电池负级 Connect Section 1 Battery negative grade
	2	B1+	接第 1 节电池正级 Connect section 1 battery level
	3	B2+	接第 2 节电池正级 Connect section 2 battery level
	接最后 1 节电池正级 Connect the last 1 positive battery level
NTC1 接口 (标配) PH2.0 3Pin	1	NTC1	1#温度线 1 # Temperature line
	2	GND	地 GND
	3	NTC2	2#温度线 2 # Temperature line
SOC indicator 电量显示 板接口 (标配) Optional accessories	1	GND	地 GND
	2	3.3V	灯板供电电源 3.3V Light board power supply is 3.3V
	3	S1	灯板按键 Lamp button
	4	LED5	灯板第 5 盏灯 Light board # 5th lamp

PH2.0 8Pin	5	LED4	灯板第 4 盏灯 Light board # 4th lamp
	6	LED3	灯板第 3 盏灯 Light board # 3th lamp
	7	LED2	灯板第 2 盏灯 Light board # 2th lamp
	8	LED1	灯板第 1 盏灯 Light board # 1th lamp
蓝牙/GPS/UART/LCD 接口 (标配) Optional accessories PH2.0 6Pin	1	GND	地 GND
	2	3.3V	供电电源 3.3V Power supply is 3.3V
	3	15V	供电电源 15V Power supply is 15V
	4	S1	灯板按键 Lamp button
	5	TX	通讯发送端 Communication sending end
	6	RX	通讯接收端 Communication receiving end
RS485/CAN 接口 (选配) Optional accessories PH2.0 5Pin	1	485_B	485 通讯接收端 485 Communication receiving terminal
	2	485_A	485 通讯发送端 485 Communication sender
	3	GND	地 GND
	4	CAN_H	CAN 通讯高 High CAN communication
	5	CAN_L	CAN 通讯低 CAN communication is low
KEY 接口 (选配) PH2.0 2Pin Optional accessories	1	TRIG+	激活输入脚 (短接 1 脚和 2 脚, 即可激活 BMS) Activate ating input foot (short 1 and 2 Will activate BMS)
	2	TRIG-	激活输出脚 Activate the output foot
软开关接口 (选配) PH2.0 2Pin Optional accessories	1	DI1	开关量信号 Switch quantity signal
	2	3.3V	供电电源 3.3V Power supply is 3.3V
Reserved interface 预留 DIO 口 (选配) Optional accessories PH2.0 6Pin	1	DO1	开关量信号 Switch quantity signal
	2	GND	地 GND
	3	DI2	开关量信号 Switch quantity signal

7.2 主要线材说明

线材名称 Line name	默认规格 Default specification
B- P-线 Output Line	3135 7AWG L=85mm M6 端子
采集线 Collecting line	1007 24AWG L=450mm (17PIN)
NTC 线	24AWG L=250mm

8. 接线示意图 Schematic diagram of wiring

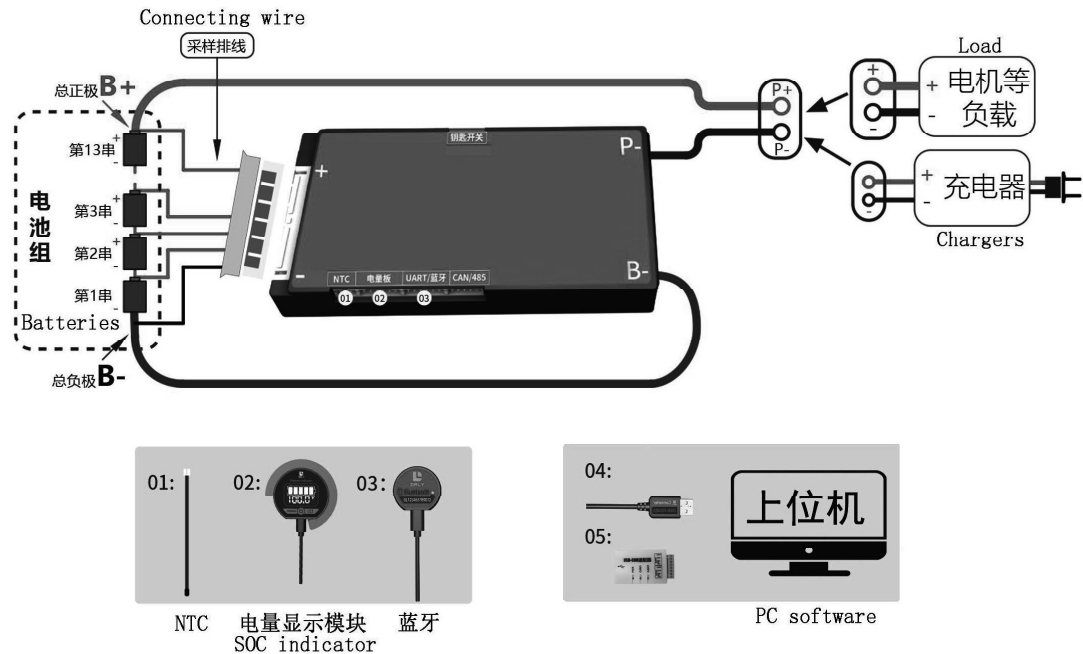

8.1 接线说明 Description of wiring

- 先将保护板 B-线（蓝色粗线）到电池组总负极；
First connect the B-cable of the protection board to the total negative pole of the battery pack
- 排线从细黑线连接 B-开始，第 2 根线连接第 1 串电池正极，后面依次连接每一串电池的正极；再把排线插入保护板；
The cable starts from the thin black one connecting B-, the second red cable connects the positive pole of the first string of batteries, and the next string is connected in turn. The positive pole of the pool; then insert the cable into the protection board;
- 线完成后，测量电池 B+, B-电压与 P+, P-电压值是否相同，相同即保护板工作正常；否则请按照上面重新操作；
After finishing the wiring soldering, measure whether the battery B+, B-voltage and P+, P-voltage values are the same, only same, the protection board works positively. otherwise please follow the above re-operation;
- 拆卸保护板时，先拔排线（如果有两个排线，先拔高压排线，再拔低压排线），再拆动力线 B-。
When removing the protection board, first pull out the cable (if there are two cables, pull the high-voltage cable first, then pull the low-voltage cable), then remove Power cable B-.

8.2 接线注意事项 Precautions for wiring

- 软件板连接顺序
确认排线焊接无误之后，并且把随产品的配件（如：温控标配/电量板选配/蓝牙选配/GPS 选配/显示屏选配/定做通讯接口选配）安装在保护板上，然后再把排线插入保护板插座；保护板上面的蓝色 B-线接电池的总负极，黑色的 P-线接在充放电的负极上面。
Software board connection order
After confirming the welding is correct, the accessories with the product (e. g.: temperature control standard /

battery panel selection / Bluetooth optional / GPS optional / display selection / customized communication interface selection) are installed on the protective panel, and then the row line is inserted into the protective panel socket; the blue B-line on the protection board connects the total negative electrode of the battery and the black P-line to the negative electrode of charge and discharge.

- 保护板首次使用需要激活

方法 1: 电量板激活, 电量板的上面是有一个激活按钮的。

方法 2: 充电激活。

方法 3: 蓝牙激活

The protection board requires activation for the first time Method:

Method 1: the SOC indicator Activation, the electricity board above is to have an activation button.

Method 2: Charge and activate.

Method 3: Bluetooth Activation

- 参数修改

保护板的串数跟保护参数(三元、铁锂)在出厂的时候是有默认值的,但是电池组的容量是需要按电池组的实际容量 AH 进行设置的,若容量 AH 没有正确设置,则剩余电量的百分比就会不准,首次使用需充满 100%作为标定,其他保护参数也可以根据客户自身需求进行设置(不建议随意修改参数)。

Parameter modification

The serial number of the protective plate and the protective parameters (Ternary and iron lithium) have the default value when they leave the factory, but the capacity of the battery pack should be set according to the actual capacity AH of the battery pack. If the capacity AH is not set correctly, then the percentage of the remaining power will be inaccurate, the first use of the full 100% as a calibration, other protection parameters can also be set according to the customer's own needs (do not recommend any changes to the parameters).

- 排线的接线方式参照背面的硬件保护板接线流程,智能板 APP 修改参数出厂密码: 123456

The wiring mode of the line arrangement refers to the hardware protection board wiring process on the back. Smart board APP modified parameter factory password: 123456

9. 保修 Warranty

本公司生产的所有锂电池保护板,质保一年;人为因素导致损坏的,有偿维修

All our produced Lithium battery BMS, we guarantee 1 years warranty in quality, if the damage is caused by human improper operation, we will conduct repair with charge

10. 注意事项 Points to note

1. 不同电压平台的保护板不能混用,如三元类保护板不能使用铁锂电池上;

Lithium battery BMS with different voltage range which can not be mixed using., Life Po4 BMS can not be used for Li-ion battery.

2. 不同厂家的排线不通用,请确保使用我们公司配套排线;

Cables from different manufacturers are not common ones, please make sure to use Daly's matching cable.

3. 在测试、安装、接触和使用保护板时,要做好防静电措施;

When testing, installing, contacting, and using the protective board, take measures to put static electricity on it;

4. 不要使保护板的散热面直接接触电芯,否则热量会传送到电芯,影响电池的安全;

Mustn't let the heat dissipation surface of the protection board directly contact the battery core, otherwise the heat will be transmitted to the battery core. which will affect the safety of the battery:

5. 不可自行拆卸、更改保护板元器件；

Do not disassemble or change the components of the protection board by yourself;

6. 本公司保护板金属散热片进行了阳极氧化绝缘处理，氧化层破坏后仍会导电，组装作业

中避免散热片与电芯、镍带接触；

The metal heat sink of the protection board of the company is anodized and insulated, and the oxide layer will still be conductive after being destroyed. Avoid contact between the heat sink and the battery core and the nickel strip

7. 如果保护板出现异常，请停止使用，等问题解决了再使用；

If the protection board is abnormal, please stop using it. Then use it again after it is checked with OK;

8. 不要让两个保护板串联或并联使用。

Do not use the two protective boards in series or in parallel

11. 特别说明 Special Instructions

我司产品进行严格的出厂检验测试，但是因为客户使用的环境不同（特别是在高温、超低温、太阳下等），难免会出现保护板故障，所以客户在选择和使用保护板时，需要在友好的环境下使用，及选择一定冗余量的保护板。

Our products is tested by our tester & 100% visual inspection before shipping. But the BMS board is used in the different environment by customers (especially at high temperatures, Ultra-low temperature, under the sun, etc.), it is inevitable that there are BMSs which will fail. Please use it in a good environment, and choose a certain amount of protection board